



CombiFlex Pro – for high demands on quality



- For universal use
- Stable square steel stand
- Height adjustable projection surface
- Fold-out mounting bracket for tilting the projection surface, approx. 10° (for keystone correction)
- Tensioning stud mechanism for optimum flatness
- Carry handle for easy transport
- Octagonal steel plate casing
- Casing colour: white aluminium, RAL 9006
- Robust tripod stand

Screen surface

- Front projection, **type D**
- DIN 19045 gain factor, approx. 1.2
- Matt white, foil base
- Back: virtually opaque

CombiFlex Professional			
External dimensions W/H	Diagonal cm/inch	Weight net kg	Code No.
150/150 cm	212/84	9.5	13005
180/180 cm	255/100	10.7	13006
200/200 cm	283/111	14.5	13007

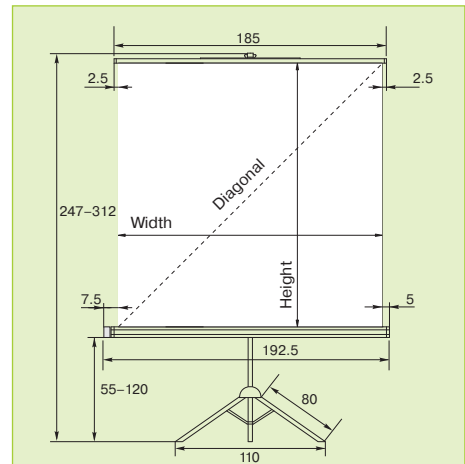

Example for Code No. 13006

CombiFlex Budget – functional basic model at a feel-good price



- Oval tube steel stand
- Infinitely height adjustable screen
- Carry handle for easy transport
- Octagonal sheet steel casing
- Casing colour: white
- Robust tripod stand

Screen surface

- Front projection, **type D**
- DIN 19045 gain factor, approx. 1.2
- Matt white, woven fabric base
- Back: virtually opaque

CombiFlex Budget			
External dimensions W/H	Diagonal cm/inch	Weight net kg	Code No.
150/150 cm	212/84	11.0	16410
180/180 cm	255/100	13.0	16411
200/200 cm	283/111	15.0	16412

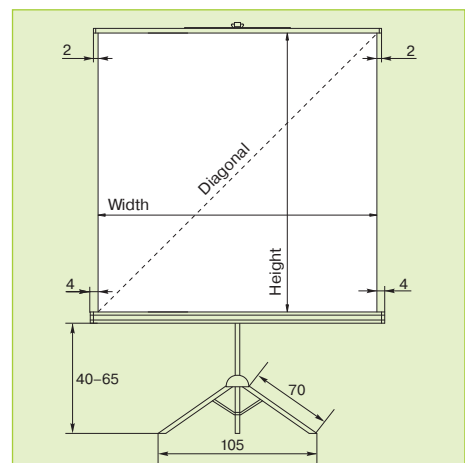

Example for Code No. 16411



Accessory

Protective cover/transport bag

For both CombiFlex Pro and CombiFlex Budget

- Made of robust nylon fabric
- Colour: black

For sizes approx. W/H	Code No.
150/150 cm	13026
180/180 cm	13027
200/200 cm	13030